

**Joinery
Products**

XL Joinery Ltd
La Porte French Doors
Specification, Warranty and Instructions

**XL Joinery Ltd
Bradford Road, Batley, West Yorkshire,
England
WF17 8NE
Tel: 01924 350500
Fax: 01924 350525
www.xljoinery.co.uk**

LA PORTE FRENCH DOORS

Product Specification

The XL Joinery La Porte French Doorsets have been designed to provide an ideal combination of performance and aesthetics. They are available in Pre-finished Oak, Prefinished White and Unfinished Hardwood options. A matching timber frame is supplied as standard. The Pre-finished Oak French Doors can also be configured to suit larger openings by ordering a matching Sidelight Frame and Sidelight(s).

Door Design:

- 54mm thick doors.
- FSC engineered timber construction.
- Factory Glazed 24mm Toughened Double Glazed Units with Low-E glass and Argon gas fill.
- Available in Pre-finished Oak, Prefinished White or Unfinished Hardwood with matching frame.
- Chrome or Brass Handles, Security Lift-Off Hinges, Aluminium Threshold and Rain Deflector.
- 5 point Multi Point Locking System, Top and Bottom Flush Bolts and Keeps, Weather Seals (in brown), and Frame Assembly Screws.
- Matching timber weather-bars are supplied with all doors as an alternative to the Aluminium Rain Deflector.
- Standard Opening Configuration: Doors open outward with a left hand locking door opening first, as viewed from outside the building. Doors can be rotated 180 degrees to have a right hand locking door.
- Non-Standard Opening Configuration: Doors and Frame can be assembled at owners own risk to open into the building. **Note:** The loose glazing bead will be located to the outside of the building and this may affect both physical performance and household insurance eligibility. This configuration may also impact on U-value performance. **The warranty may be invalidated.**

Performance:

- Stated U-Values are based upon a 2.0m x 2.0m opening size for the purposes of Part L of the Building Regulations:
 - Softwood White Finished French Doors: **1.5W/m²K**
 - Oak and Hardwood French Doors: **1.7W/m²K**

Guarantees



10 Years Guarantee
against Manufacturing
Defects



10 Year Guarantee against
Double Glazing Unit Failure

Warranty Information

The warranty offered on the XL Joinery La Porte French Doorsets is based on the following conditions:

- The product has been installed correctly and has not been inappropriately modified before, during, or after installation.
- The product has been stored and handled in accordance with XL Joinery guidelines.
- The product has not been damaged due to improper storage, installation, use or maintenance.
- The product is fit for its intended use and location, (e.g. not used as a load bearing item).
- Suitable ventilation was provided during and after installation to regulate moisture content.
- The paint/ stain finish has not failed due to inadequate maintenance or poor installation.
- The paint/ stain finish has not been exposed to physical or chemical damage, e.g. ladders, cleaning agents etc.
- Unfinished products have been treated in accordance with XL Joinery Finishing Guidelines.

Elevation and Section Details

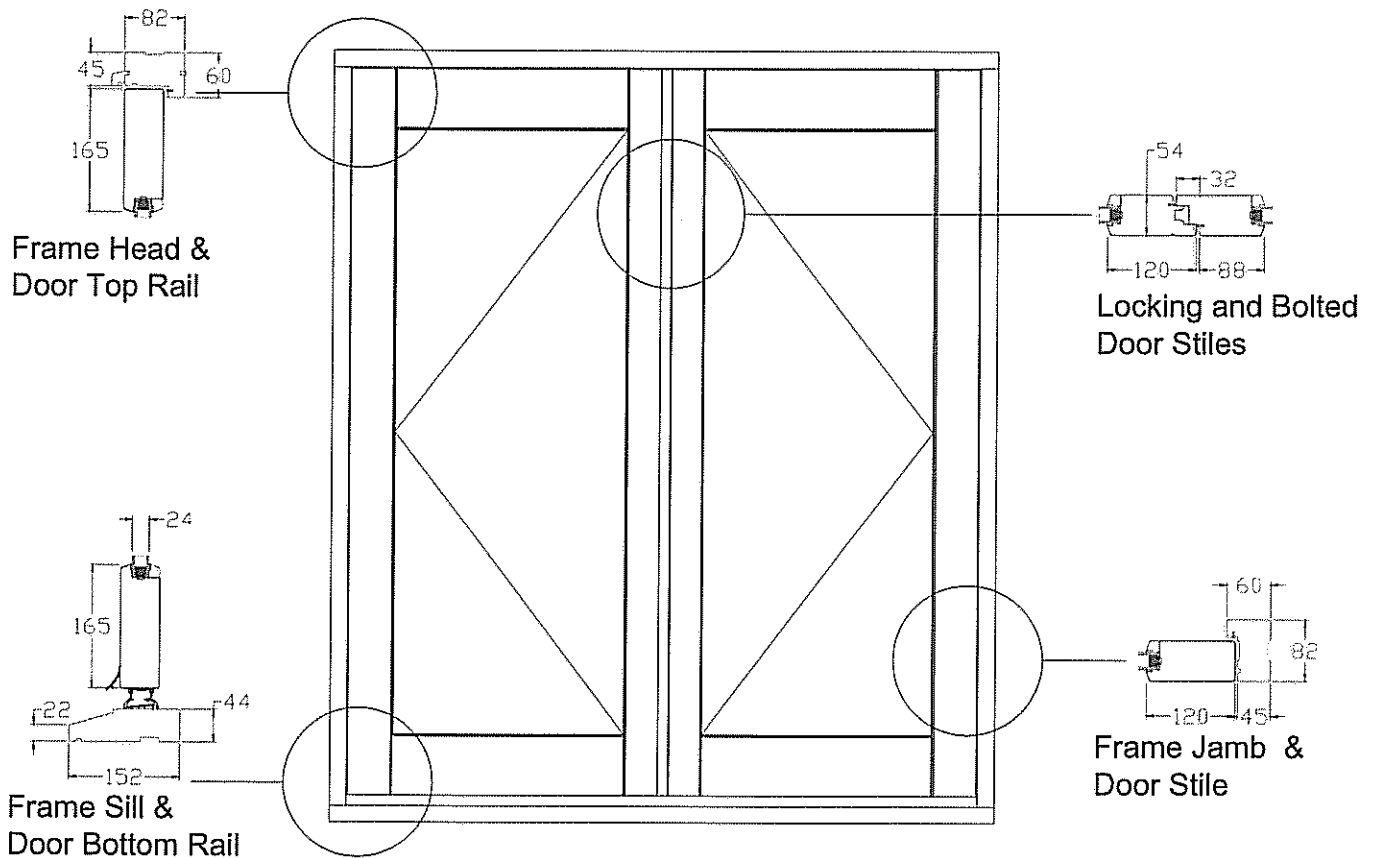

SAFETY IN USE

Glass Caution

Warning! This product contains glass components which, if broken, can cause serious injury. Use extreme caution and keep children away from broken glass.

Tempered Glass Characteristics

Tempered glass is called "safety glass." It is more resistant to breakage than normal float glass and if it is broken, breaks into relatively small, blunt particles, which are less likely to cause injury. It is approximately five times stronger than annealed glass of equal thickness. Greater resistance to thermally induced stress than heat strengthened or annealed glass. Suitable for use as a safety glass. Tempered safety glass is mandated in many window applications and all door applications. Suitable where safety glazing is required, for fire knockout panels, all glass entrances and where extreme wind loads are a concern.

Hardware

Ensure that all fittings function efficiently and are regularly maintained to prevent debris impeding the function of the doors: Failure to do so may result in improper or incomplete functioning of the hardware and potentially restrict the safe operation of the doors.

Fall Prevention

Warning! An open door is a possible fall hazard, particularly when located in an elevated position above ground floor level, e.g. first floor balcony. Where necessary, ensure door openings are protected by suitable guard rails or similar.

LA PORTE FRENCH DOORS

Instructions

The XL Joinery La Porte French Doorsets are designed and manufactured using cutting edge technology to produce a high performance product. However, the manner in which they are handled, stored, installed and maintained can affect their performance and compromise their service life. Please ensure that you read and understand the following instructions.

STORAGE AND HANDLING

- Check packaging for visible damage on delivery: Inspect the product and notify your merchant immediately if the product is damaged.
- Store the product off the ground on suitable, level bearers.
- Cover the product to avoid damp, dust and other contaminants.
- Storage areas should be well ventilated and not subject to extremes of temperature.
- Avoid **unsuitable** storage such as metal box containers and areas open to the elements. These may be subject to condensation and very high temperatures in direct sunlight. Water can also collect in the protective packaging leading to saturation of some components.
- A building, which has been built or renovated, using processes such as concreting, plastering, rendering, etc., will have a very high humidity level until dried and ventilated. If the product is installed prior to completion of these 'wet' processes, the high residual humidity will force moisture to penetrate the joinery from the inner face thus increasing the moisture content of the timber. Gentle internal heating and good ventilation of the building will greatly reduce the problem.
- Plaster and other building materials can also cause contact damage to protective coatings. If contamination occurs then remove as soon as possible with a solution of mild detergent and rinse with clean water.
- Ensure that any on site assembly or modifications are fully protected. This particularly applies to sill joints, glazing beads and glazing systems. Areas of unprotected end grain exposed by site modifications must be properly sealed and protected by brushing a generous coat of timber end grain sealant onto the exposed area.
- You should take extra care when fitting factory finished products in order to avoid damaging the coating. If you cut or damage the timber when installing the window, it must be treated with a compatible protective treatment.

PAINTING OR STAINING

- **Pre-Finished La Porte French Doorsets require regular maintenance as per the MAINTENANCE section of this document.** Periodically check the finishing treatment and touch up as necessary. To ensure the long life and appearance of the La Porte French Doorset, retreat every few years.
- Before the frame and doors are fitted, all components must be treated in accordance with the finishing instructions.
- All timber surfaces on the frame and doors must be given a total of three coats of high performance wood- stain or paint. It is important to apply the treatment to the doors and frame before they are installed.
- Failure to treat all the timber surfaces before installation may lead to excessive changes in moisture content which will cause the timber to shrink or swell, perhaps causing splits and distortion.
- When applying the stain pay particular attention to sealing the timber end grain on the tops and bottoms of the frame, side and doors and the ends of the sill.
- Also ensure that the lock and hinge cut outs are stained the same as the timber surfaces, and in particular the undersides (unseen faces).
- In areas of severe exposure, external doors should be protected by a canopy or porch in addition to pre-finishing.

PRE-FINISHING SUMMARY

DO

- Use a "High Build" stain or good quality exterior paint
- Apply a minimum of 3 coats to all faces and edges (in severe exposure conditions apply an extra 2-3 coats)
- Apply the same number of coats applied to the face and edges of the door to the top and bottom edges, lock, hinge and letter plate cut-outs
- Apply at least 2 coats immediately upon unpacking the door
- Check that paint or stain manufacturers' product is suitable for veneered/ engineered doors

DO NOT

- Use thin penetrating seals, oils or stains and hard, brittle paints, varnish or wax
- Apply stains or paints in damp / wet weather
- Use "Low Build" stains or thinned paint
- Mix incompatible products

Note: Cutting, damaging or finishing the product in a manner not detailed in these instructions may invalidate the warranty.

INSTALLATION

Prepare the Opening.

It is strongly recommended that old doors and windows should not be removed, nor apertures created, until all new materials are on site. This avoids the building being open and insecure for any longer than necessary. **REMEMBER:** Check the product for any damage or missing parts prior to commencing installation.

It is the installer's responsibility to ensure that the door frame is fitted under a suitable lintel or other structural support and that an appropriate damp-proof course/ bedding, is installed at sill level.

The brickwork opening should be approximately 10mm wider than the assembled frame dimensions. Ensure that the brickwork is level and the opening square prior to installing the frame: Failure to do so may result in the frame being out of square which can impede the proper functioning of the doors.

FRAME DIMENSIONS

The **T4SET** external frame dimensions are: 2074mm high x 1190mm wide
Approximate brickwork opening dimensions should be: 2084mm high x 1200mm wide

The **T5SET** external frame dimensions are: 2074mm high x 1490mm wide
Approximate brickwork opening dimensions should be: 2084mm high x 1500mm wide

The **T6SET** external frame dimensions are: 2074mm high x 1790mm wide
Approximate brickwork opening dimensions should be: 2084mm high x 1800mm wide

The **MAXIMUM SIDELIGHT FRAME*** external frame dimensions are: 2074mm high x 3044mm wide**
Approximate brickwork opening dimensions should be: 2084mm high x 3054mm wide**

***The Sidelight Frame is a multi-purpose product that is intended to be adapted by the installer to fit a multiple range of sizes and opening configurations: It is the responsibility of the installer to ensure that the required dimensions and assembly are suitable for the products intended use.**

** (Dimensions are based on a **SIDELIGHT FRAME**, Pair of **T6SET** Doors and 2 x 590mm wide **SIDELIGHTS** including suitable clearances between components)

BRICKWORK OPENING

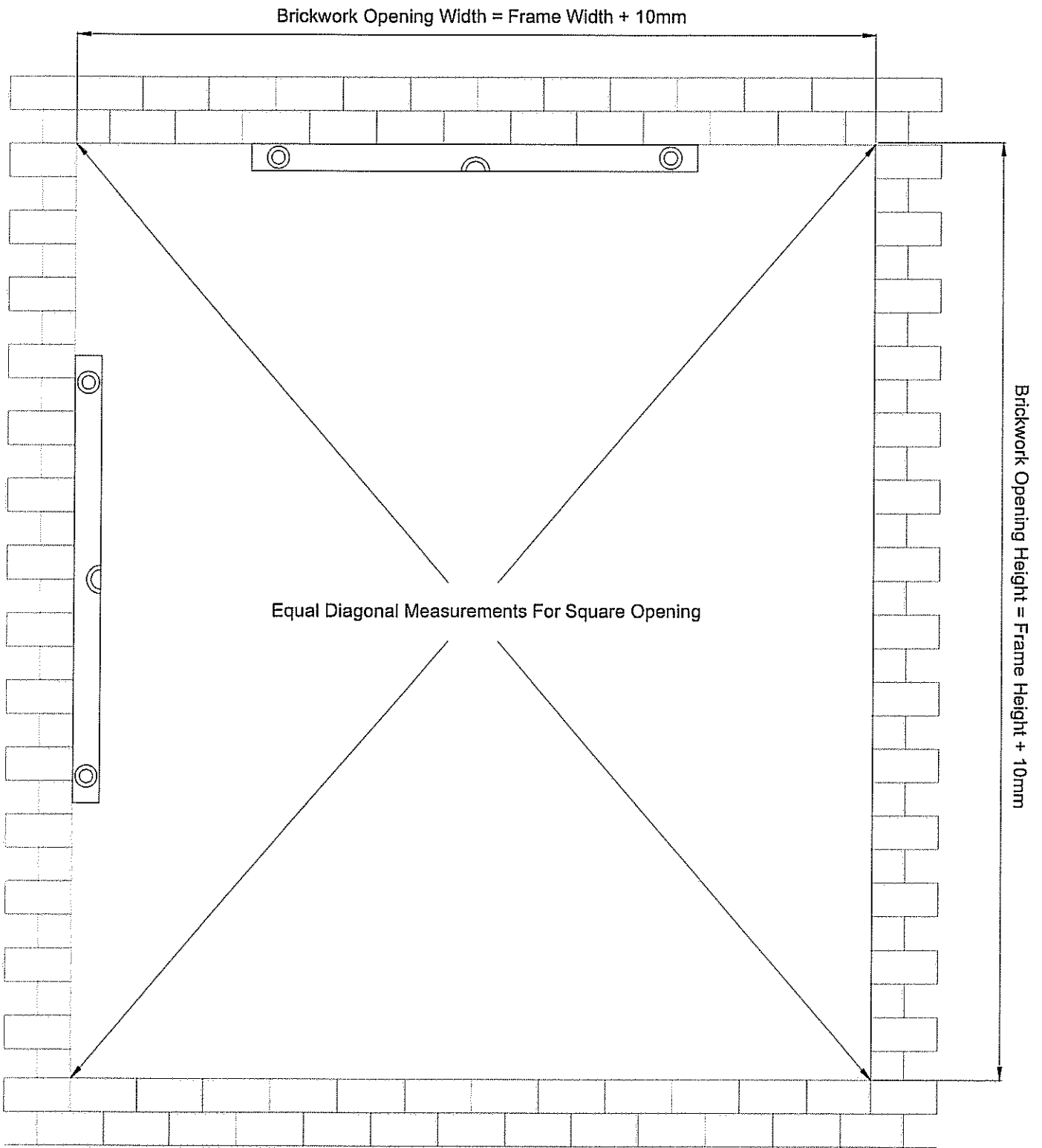

Assemble the Frame

Decide if your doors are to Open In or Open Out from the building:

Assemble the frame with the Rebate Shoulder to the inside of the building if the doors are to open outwards.

Assemble the frame with the Rebate Shoulder to the outside of the building if the doors are to open inwards.

The Frame Head, Sill and Jambs are pre-drilled to accept the screws provided.

- Loose assemble the Frame components, ensuring that all joints are tight fitting and flush and the frame square.
- If using a SIDELIGHT FRAME, Pre-drill through the Frame Head and Sill components and into the Jambs/ Mullions using a 4mm wood drill bit after determining the position of the French Doors and Sidelight(s).
- Apply a waterproof adhesive to the joining surfaces between the Jambs/ Mullions and the Sill and Head components just prior to screwing the jointed components together.
- Use the No.10 x 100mm Sill Frame Assembly Screws to connect the Jambs/ Mullions to the Sill and Head components through the pre-drilled holes.
- Ensure the frame joints are tight and that the frame is square throughout the installation.
- Wipe off any excess adhesive with a clean cloth.
- **DO NOT** fit the Head Drip Infill Bead and Drip Bead Moulding until the doors have been hung.
- If necessary, cut off the protruding horns from both ends of the Sill and Head to fit the brick opening.

DOOR OPENING DIRECTION

Doors Open Out From The Building

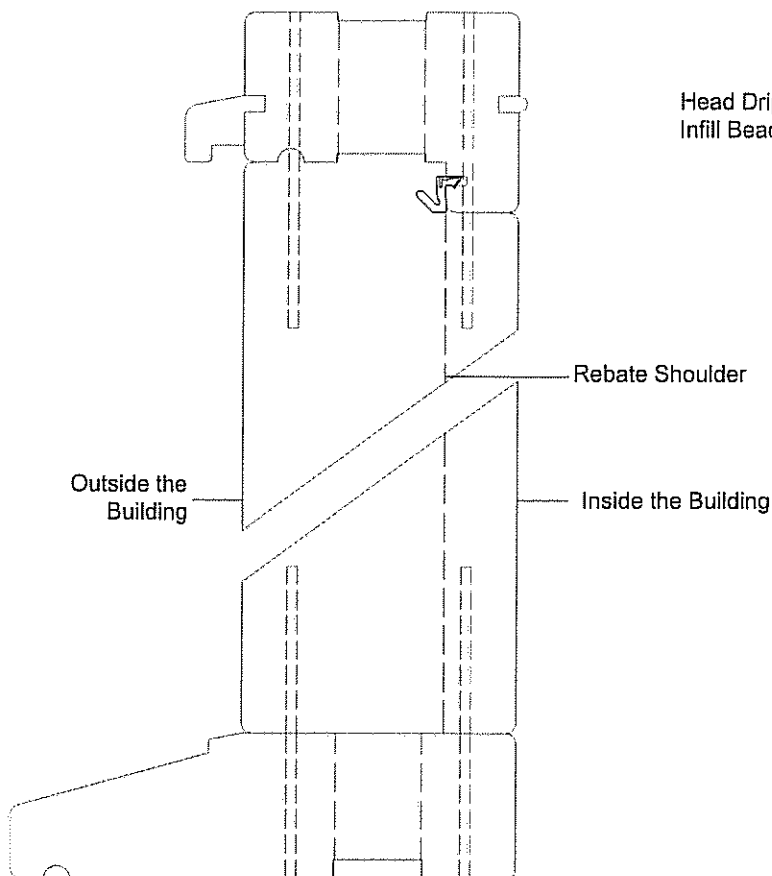

Doors Open Into The Building

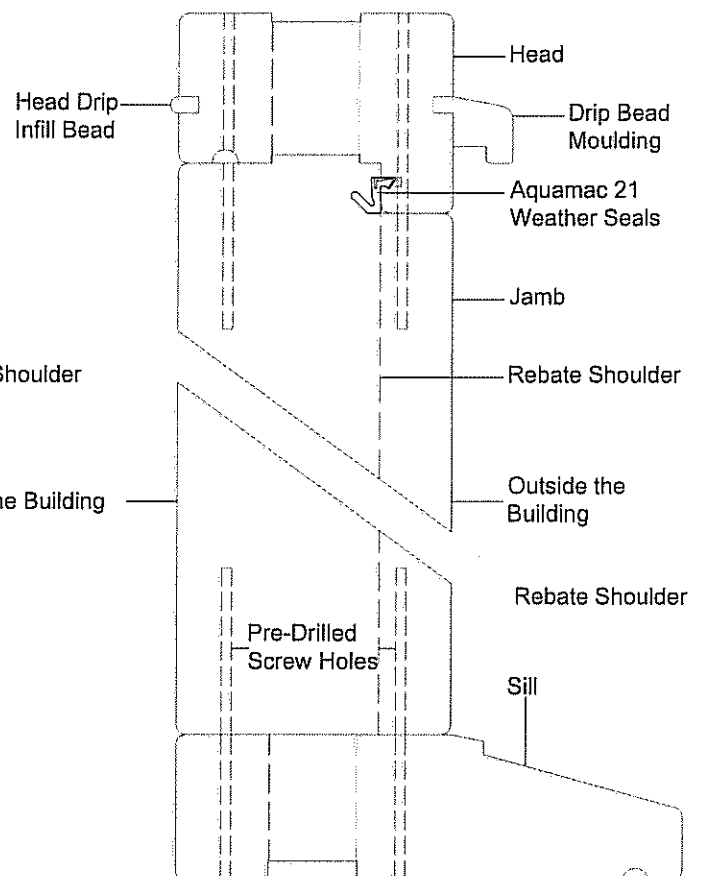

Install the Assembled Frame

- Fit the frame into the brickwork with the sill facing to the outside of the building, ensuring that the frame overhangs the brickwork cavity.
- Situate the Sill on an appropriate damp-proof course/ bedding. Ensure that the sill extends beyond the external face of the brickwork to allow water to drain away freely. Fully Damp Proof Courses should be fitted during construction of the aperture. .
- To reduce the amount of heat lost from the inside of the building to the outside through the frame edges, (Technically known as "a cold bridge"), the frame must be set back to overlap the inner face of the outer brickwork **by at least 30mm**. Adequate insulation should be fitted between the outer and inner wall construction to reduce heat loss around aperture.
- Ensure that the frame is fitted square and level in both the horizontal and vertical plane: Use wooden / plastic packers between the frame and brickwork opening.
- Check that the frame diagonal measurements are equal to ensure that it is square.
- Fit the frame through the Jambs and into the surrounding structure using suitable frame fixings, (not supplied). Drill and countersink the Jamb fixings at 150mm from the top and bottom of the frame with a minimum of five evenly spaced fixings in each of the Jambs. Frame fixings can also be installed at both the Head and Sill, particularly to secure wider installations such as a Sidelight Frame.
- When tightening the screws use wooden / plastic packers to prevent the frame from distorting
- If the frame is installed into a timber frame construction, allowance must be made for differential movement between the various construction components.

FIXING THE FRAME

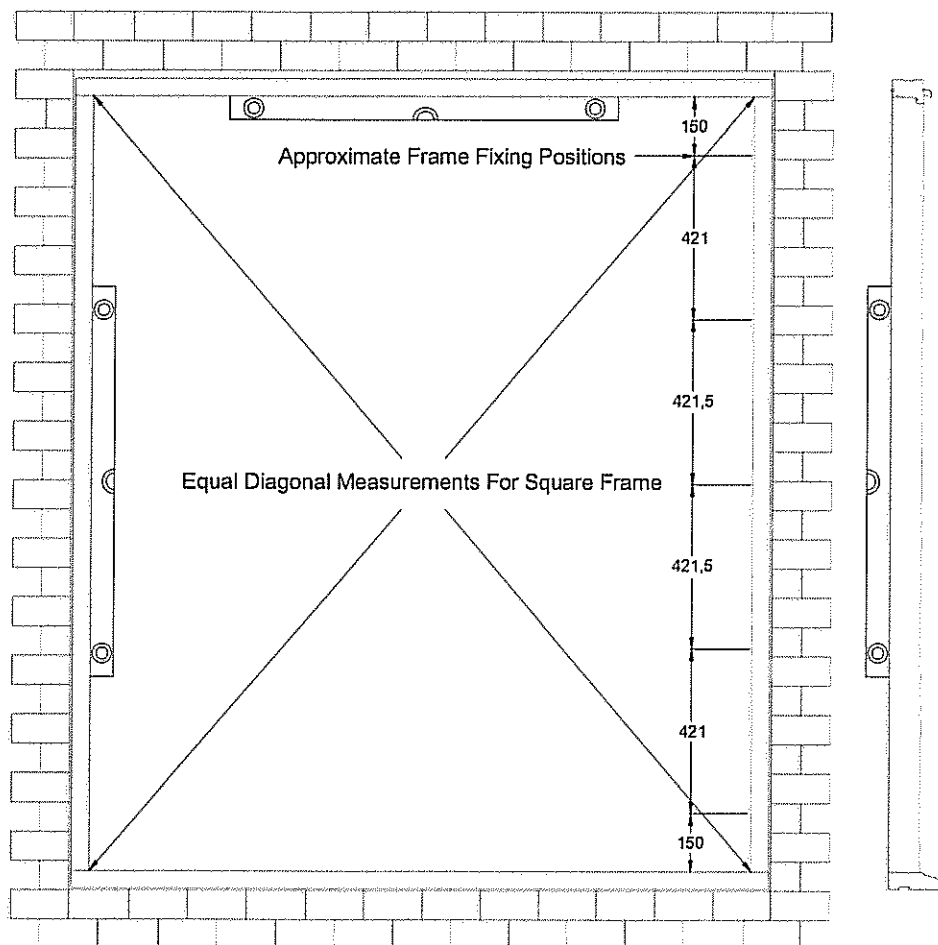

Sealing

To prevent air and moisture passage between the frame and the adjacent wall, the gap should be fully sealed. Various sealing methods can be used, e.g. expanding closed cell foam or a silicone or mastic sealant. If excess sealant spreads over the painted surface, in order to avoid damage, clean it off as soon as possible: Do not allow it to set.

Hanging the Doors

- Fit the Weather Seals into the Frame Grooves. Cut the Weather Seal so that it covers the full length of the Frame Head groove. The vertical Weather Seals should butt up to the underside of the horizontal weather seal and run down the Frame Jamb and end at the Sill.
- Fit the Lift-Off Security Hinge plates into the pre-formed hinge cut-outs in the Frame Jamb: Pre-drill the holes prior to securing all six hinge plates using the 40mm screws supplied. The hinge blade with the protruding shaft must be fitted to Frame. The hinge blade with the hollow barrel must be fitted to the door.

NOTE: If using a **SIDELIGHT FRAME**, the Frame Mullions have pre-formed hinge cut-outs; however the Frame Jamb do not. This allows a Sidelight to be fixed adjacent to a Frame Jamb without the need to fill the hinge cut-outs. If a door or hinged Sidelight is to be fixed adjacent to a Frame Jamb, it will be necessary to form the hinge cut-outs during installation.

- Fit the Lift-Off Security Hinge plates into the pre-formed cut-outs in the Door Leafs: Pre-drill the holes prior to securing the hinge plates using the 40mm screws supplied.

FIXING THE HINGES

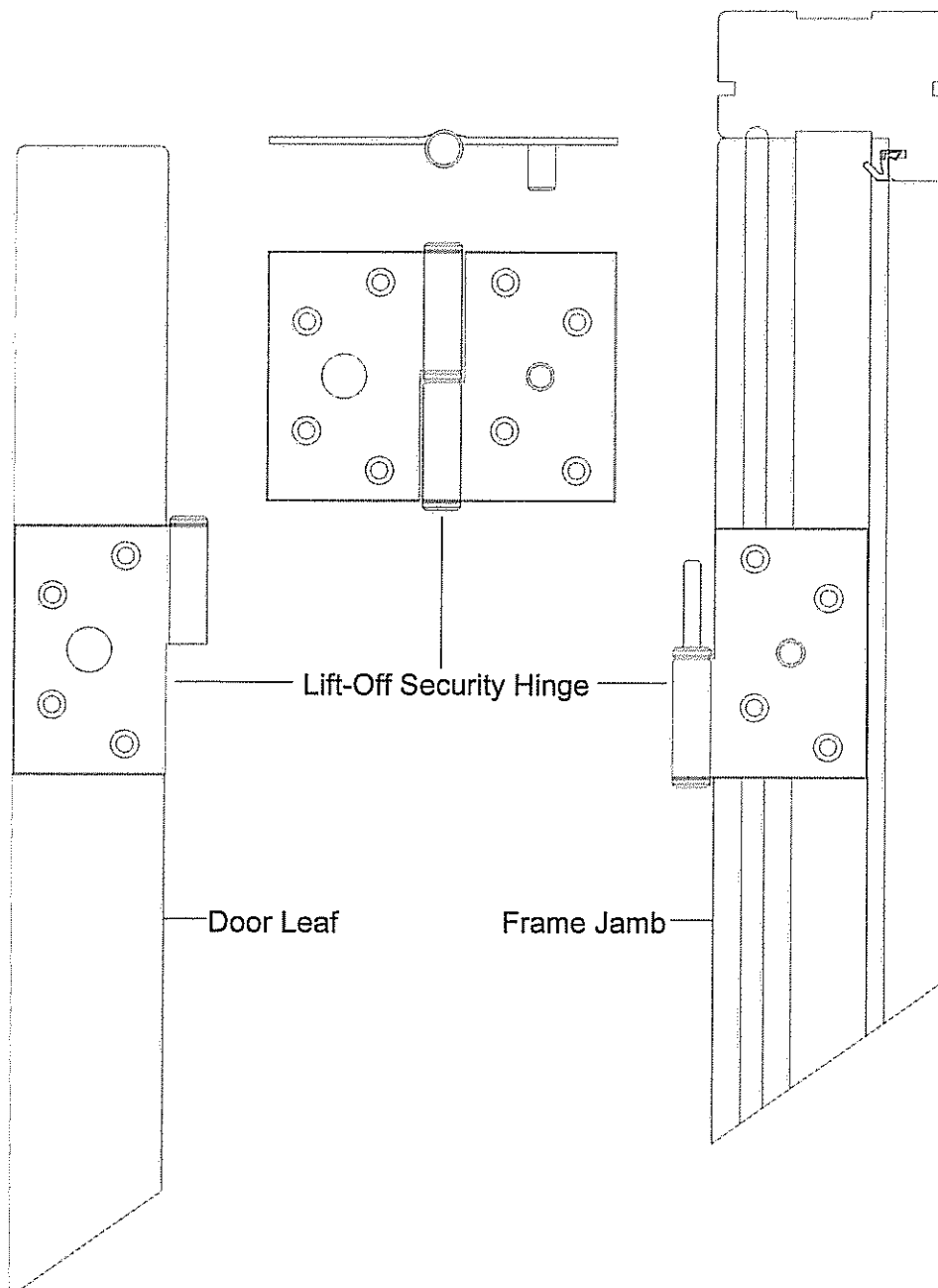

- Fit the Top and Bottom Flush Bolts:
 - Fit the bolts into the pre-formed cut-outs in the Bolted Door Leaf
 - Pre-drill the holes prior to securing the bolts with the screws provided: The Bottom Flush Bolt has an Extended Shootbolt of 22mm to allow the shootbolt to extend into the Aluminium Sill Threshold.
- Fit the Aluminium Threshold Strips to the bottoms of the Locking and Bolted Door leaves prior to hanging the doors: The Aluminium Threshold Strips are supplied uncut to allow for different opening configurations:
 - Cut the Aluminium Threshold Strips with a hack saw around the door rebate to the dimensions in the diagram below, ensuring that the Brush Draft Excluder faces to the outside of the building.
 - The Bolted Door Aluminium Threshold Strip will partially cover the Bottom Flush Bolt; however it must not impede the smooth operation of the shootbolt.
 - Silicone seal between the Aluminium Threshold Strips and the bottom of the Locking and Bolted Door leaves, prior to securing with the screws provided.

NOTE: If using a **SIDELIGHT FRAME**, the Aluminium Threshold Strips will need to be fitted to the Sidelight(s), prior to installing them into the Frame.

FIXING THE FLUSH BOLTS AND THRESHOLD STRIPS

1. FIT TOP AND BOTTOM FLUSH BOLTS

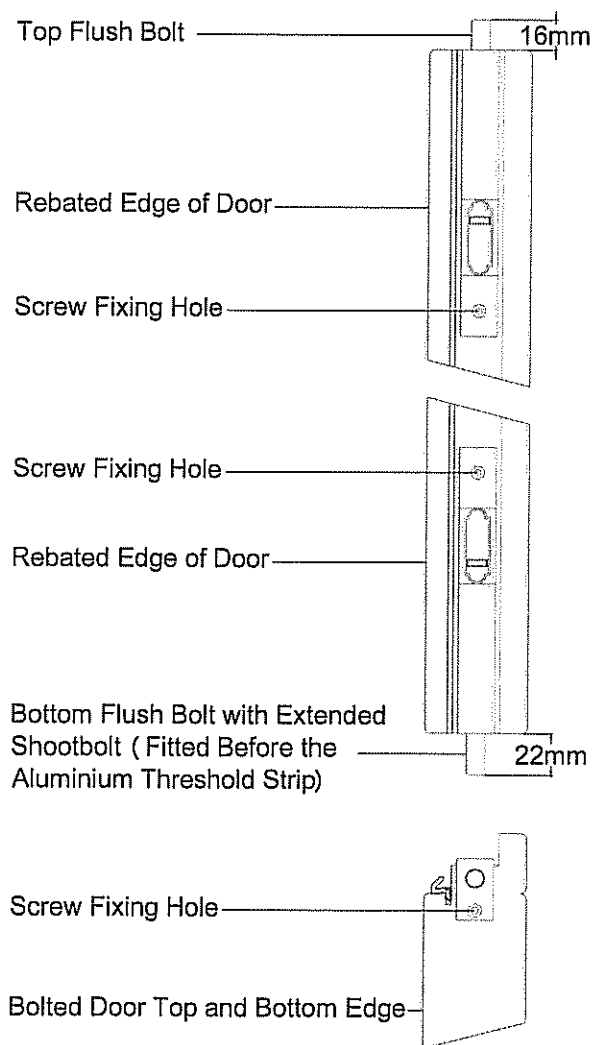

2. FIT ALUMINIUM THRESHOLD STRIPS

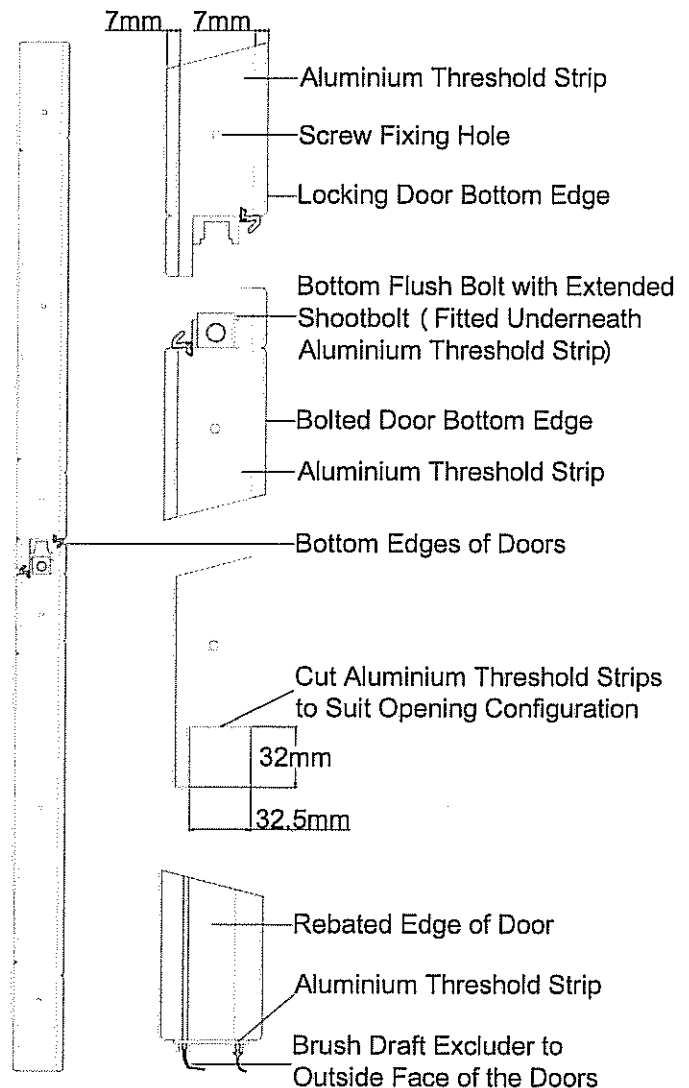

- Hang the Locking and Bolted Door leaves in the Frame:
 - Lift each door into position and slot the hollow barrels of the door hinges over the Frame hinges with the protruding shaft.
 - Close the Bolted Door first and then the Locking Door to ensure that the doors are positioned correctly in the frame.
 - Double check the Frame squareness by checking the gap around the doors: If both doors do not line up along the horizontal top edge, the Frame squareness can be adjusted by using wedges under the sill. If the Doors are significantly out of square or appear twisted, i.e. the door rebates do not close together along their full length when closed, then the Frame may not be installed square and plumb and would require adjustment.

- Fit the Weather Seals into the Locking and Bolted Door vertical grooves, trimming them to ensure that they run the full length of the doors.

- Fit the Top Flush Bolt Keep into the Frame Head:
 - Ensure that the keep is located so that the external face of the Bolted Door is flush with face of Frame.
 - Pre-drill the holes prior to securing the keep

NOTE: If using a **SIDELIGHT FRAME**, there is no predrilled mortice in the Frame Head to receive the Top Flush Bolt Keep and its shootbolt: The position of the doors is determined by the installer and it will be necessary for the installer to locate and cut-out for the hardware accordingly.

- Fit the Aluminium Sill Threshold and Bottom Flush Bolt Keep onto the Frame Sill:
 - The Aluminium Sill Threshold is fitted with the drainage holes facing to the outside of the building.
 - Locate the Bottom Flush Bolt Keep centrally inside the Aluminium Sill Threshold channel.
 - Ensure that the Bottom Flush Bolt shootbolt engages smoothly into the Bottom Flush Bolt Keep whilst the Top Flush Bolt shootbolt is also engaged into the Top Flush Bolt Keep.
 - When the Aluminium Sill Threshold and Bottom Bolt Keep locations are optimized secure them to the Frame Sill: Silicone seal between the Aluminium Sill Threshold and the Frame Sill, prior to pre-drilling and securing with the screws provided.

- Fit the 1 Piece MPL Keep to the Bolted Door:
 - The 1 Piece MPL Keep is located between the Top and Bottom Flush Bolts.
 - Locate the keep so that the MPL Lock latch will engage against the Keep humps when door is closed.
 - Pre-drill the holes prior to securing the keep to the Bolted Door using the 25mm screws provided.

- Fit the MPL Lock and Handles to the Locking Doors:
 - Drill out MPL lock key-hole, handle spindle, and handle fixing screws through the locking door stile using the relevant Handle Template at the end of these instructions. Note: The door latch may require to be turned around. If required, undo the two screws on the latch and spin it around and re-tighten the screws
 - Fit MPL Lock with the screws provided, pre-drilling as necessary. Do not over-tighten the screws during fitting, e.g. by using a power drill driver with the incorrect torque setting. Excessive deflection of the MPL lock will impair its smooth function.
 - Fix the handles to the locking door using the screws provided with the key-hole cover to the outside of the building.
 - With the door in the open position lift the handle upwards to ensure that the shootbolts eject properly and the lock hooks operate: Check that the key also works and that the door can be locked and unlocked. Retract the shootbolts by moving the handle downwards
 - Close both doors, ensuring that the Flush Bolts are engaged: Lift the handle to ensure that the MPL Lock shootbolts engage smoothly into the Top and Bottom Bolt Keeps: If necessary, adjust the keeps until both the Flush Bolts and MPL Lock shootbolts engage.
 - If the MPL Lock latch is not engaging into the 1 Piece MPL Keep, adjustment is made by filing down the hump on the keep until the latch snaps into place: The hump on the slot for the deadbolt may also have to be filed down if it does not engage correctly.
 - With both doors closed and the shootbolts engaged, turn the key to ensure that the door locks and unlocks.

- Fit the Aluminium Rain Deflectors and End Caps to the outside face of the doors (and Sidelights):
 - Tap the plastic end-caps onto the ends of the deflectors prior to fitting.
 - Locate the deflector on the bottom of the door and screw through the deflector holes located in its underside and into the bottom rails of the doors: Pre-drill the holes prior to securing the deflector with the screws provided.

NOTE: Matching Timber Weather Bars are supplied as a secondary option. These will require cutting, pre-drilling and securing to the outside faces of the Bolted and Locking Doors (and Sidelights): It will also be necessary to paint or stain the ends of the weather bars after cutting. It is advised that a bead of silicone is applied between the door and weather bar and along the top edge to prevent moisture build-up between the components.

The Aluminium Rain Deflectors and Timber Weather Bars must be fitted as they act to deflect moisture away from the underside of the doors and onto the Frame Sill: Failure to fit them can invalidate the warranty.

- Fit the Head Drip Infill Bead and Drip Bead Moulding into the Frame Head grooves:
 - The Drip Bead Moulding should be fitted to the outside of the building.
 - The Head Drip Infill Bead should be fitted to the inside of the building.
 - Apply silicone or wood adhesive in the Frame Head grooves and push the component into place: If necessary, further secure with small oval headed nails, pre-drilling the components first.

FIXING THE FLUSH BOLT KEEPS, ALUMINIUM SILL THRESHOLD, 1 PIECE MPL KEEP, ALUMINIUM RAIN DEFLECTOR, DRIP BEAD MOULDING AND HEAD DRIP INFILL BEAD

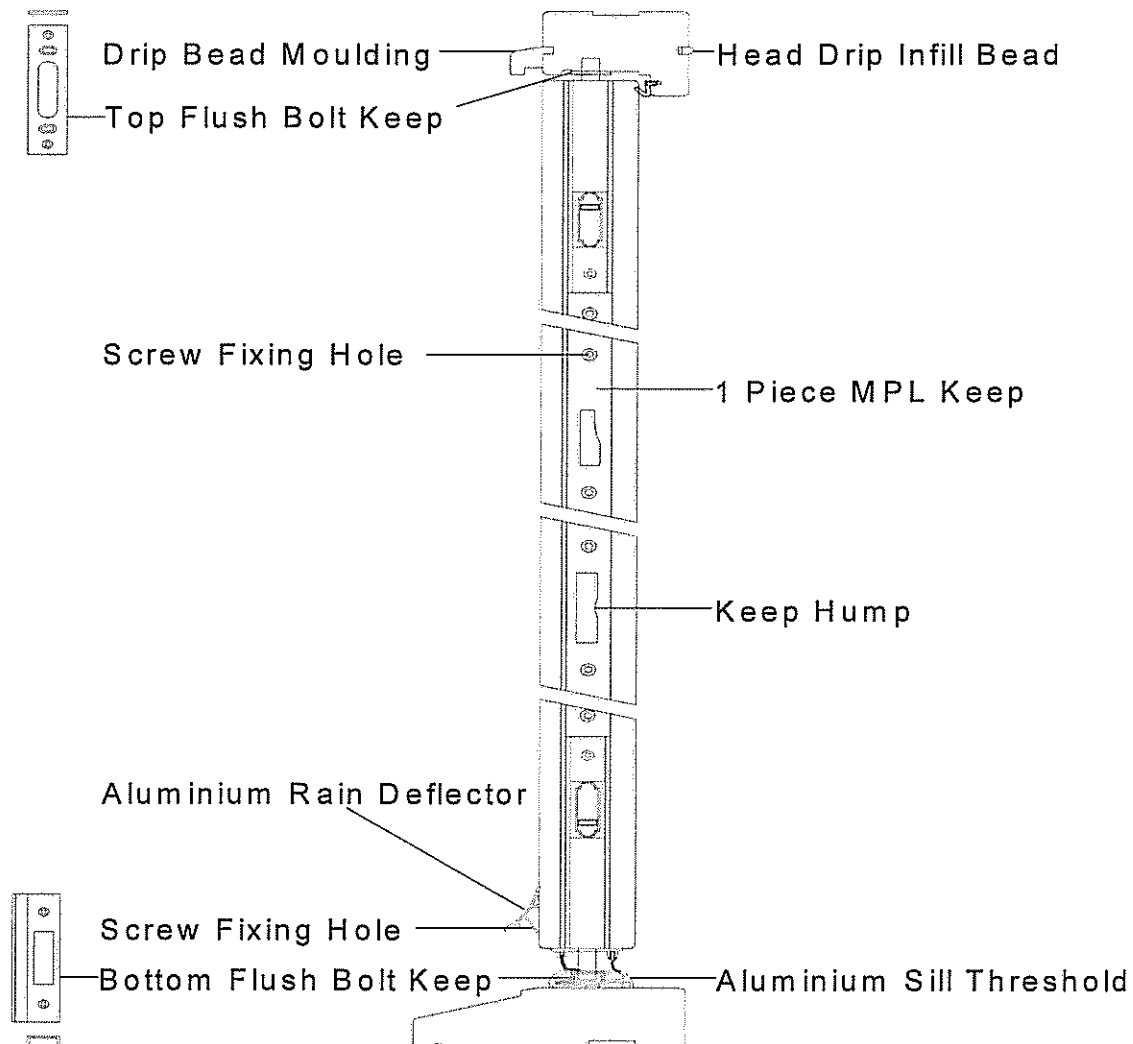

MAINTENANCE

Care and Protection by User

With proper care and attention, XL Joinery La Porte French Doorsets will give years of excellent service. To achieve this performance, the following should be observed:

- At least once per year all coatings should be washed with mild detergent and water to remove any surface pollution. Do not use a pressure washer for cleaning.
- All hinge mechanisms, locks and handles should be checked at least biannually for ease of operation and lubricated with light oil suitable for the purpose as required.
- Weather seals should be cleaned at least once per year to remove any dirt or grime.
- Ensure the Aluminium Sill Threshold is clean and that there is no build up of dirt or other impediments.

Factory Painted & Stained Finish

The schedule specified in the table below should be followed to maintain the finish. No recoating should be required during this period provided the finish is not damaged. In rare instances, extremes of exposure may necessitate recoating at an earlier stage.

| MAINTENANCE SCHEDULE | | | |
|---|--|---|---|
| CLIMATE | | | |
| | Moderate: Typically non-coastal areas at low altitude | Harsh: Exposed inland locations and areas within ½ a mile of the coast | Extreme: Exposed coastal sites and high altitude areas |
| Sheltered, e.g. protected by a porch, canopy or overhanging roof | Re-coat every 6-8 years | Re-coat every 6-7 years | Re-coat every 5-7 years |
| Part Sheltered, e.g. fitted behind exterior brickwork reveal | Re-coat every 6-8 years | Re-coat every 5-7 years | Re-coat every 3-5 years |
| Unsheltered, e.g. fully exposed face of the building | Re-coat every 5-7 years | Re-coat every 3-5 years | Re-coat every 3-5 years |

The finish coat should be washed down with clean water to remove dust, insects and other contaminants, as these can form a base for algae and fungi growth. The coating surface should be inspected for mechanical damage and affected areas repaired accordingly. When carrying out any coating work, do not attempt to paint when the temperature is below 8 degrees Celsius or if the relative humidity exceeds 85%. The curing and performance of the coating may be impaired. Please refer to the coating manufacturers' instructions for further information

XL Joinery Ltd
Bradford Road, Batley, West Yorkshire,
England
WF17 8NE
Tel: 01924 350500
Fax: 01924 350525
www.xljoinery.co.uk

