

**FITTING INSTRUCTIONS - NOTICE DE POSE - MONTAGE HANDLEIDING - MONTAGEANLEITUNG
ISTRUZIONI DI MONTAGGIO - INSTRUCCIONES DE MONTAJE**

Warranty. This product is covered by a 10 year manufacturer's warranty. Please see the P C Henderson website for terms and conditions.

WATCH THE INSTALLATION VIDEO

Visit: <https://www.youtube.com/watch?v=h2A0qLkul94#t=37>

Or scan the QR code using your phone



Door sizes and kits numbers - for doors up to 60kg

For doors up to and including standard door sizes	Kit number
1981mm (78") high x 762mm (30") wide doors	PDK3
1981mm (78") high x 838mm (33") wide doors	PDK4
2040mm high x 762mm wide doors	PDK5
2040mm high x 826mm wide doors	PDK6
2040mm high x 726mm wide doors	PDK7
2315mm high x 930mm wide doors	PDK10

Door thickness between 28mm and 44mm - Maximum door weight 60kg - Wall cavity 95mm

Tools required

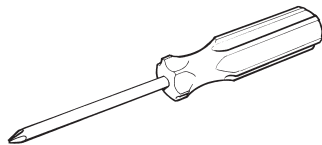

1 x Phillips screws driver

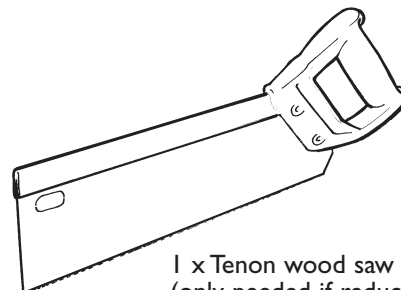

1 x Tenon wood saw
(only needed if reducing kit in size)

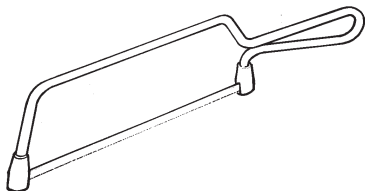

1 x Junior metal hack saw
(only needed if reducing kit in size)

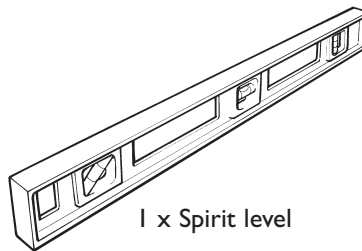

1 x Spirit level

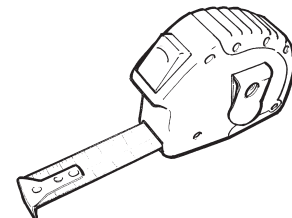

1 x Tape measure

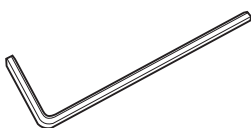

1 x Allen Key - 5mm



1 x Drill + 2mm drill bit

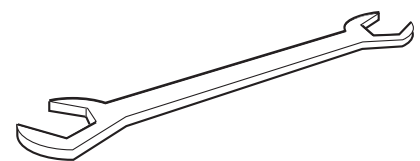
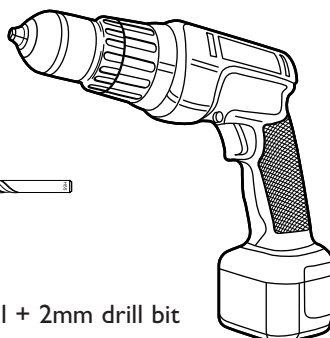

1 x Adjustment spanner

Kit components

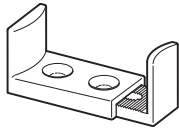

1 x Plastic guide

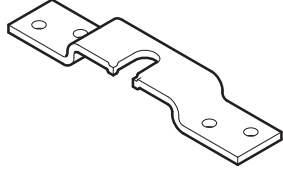

2 x Hanger apron plates



1 x Rubber stop

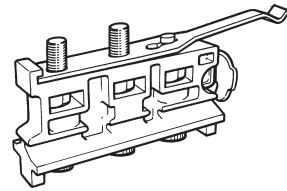

2 x Clipstops

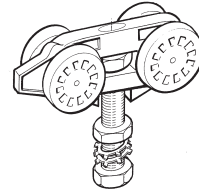

2 x Hangers



Screw A x 4
3/4" CSK. HD. Pozi
(19mm)



Screw B x 8
1" BUT. HD. Pozi
(25mm)



Screw C x 8
1 3/4" CSK. HD. Pozi
(44mm)



Screw D x 14
5/8" BUT. HD. Pozi
(16mm)



Screw E x 8
1 1/2" BUT. HD. Pozi
(38mm)

Screws shown actual size

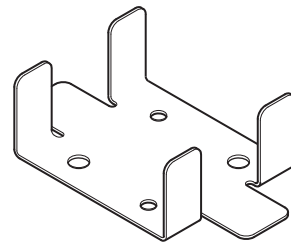

2 x Stud insert brackets

1 x Track, head and end brackets

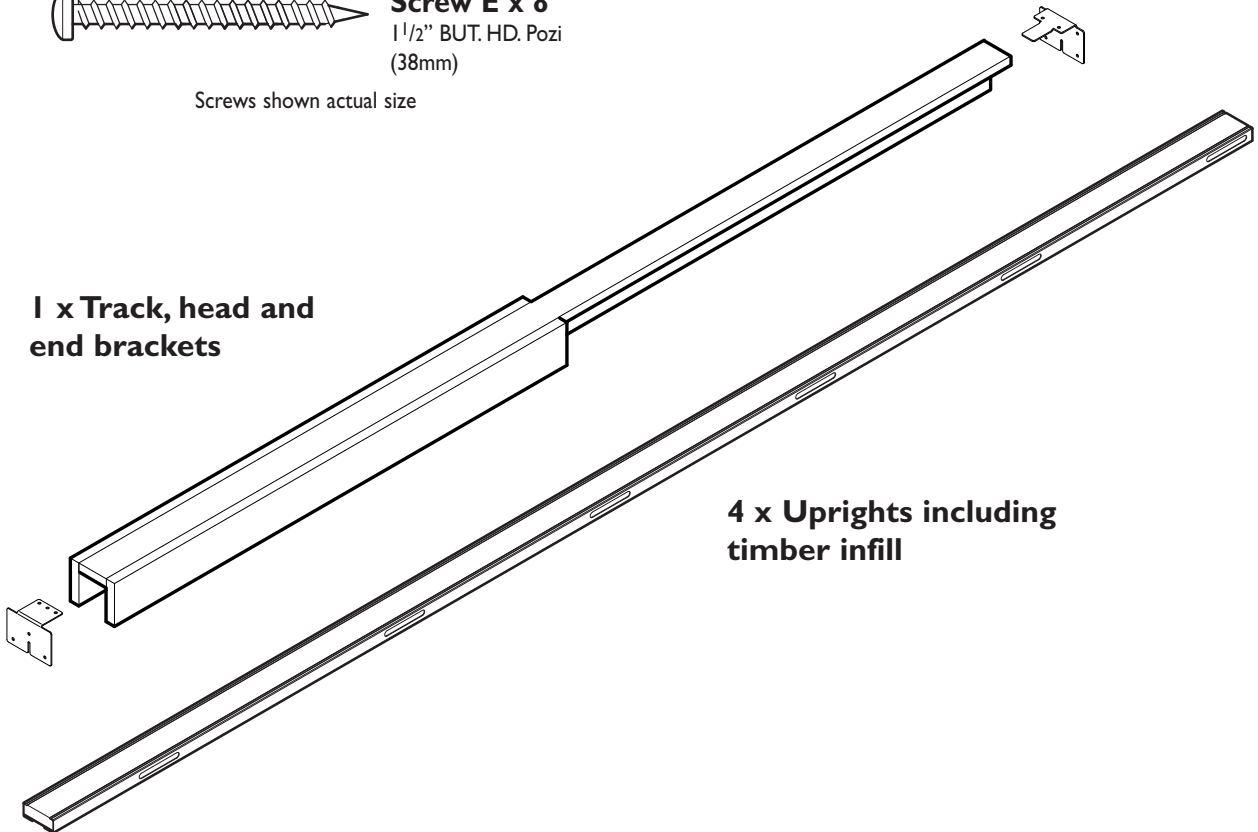

4 x Uprights including timber infill

Step I - Preparing the Rough Opening

Kit assumes installer is using standard (C10/C24) studwall timber 47mm x 100mm (actual size 45mm x 95mm)

How to calculate the opening width required

Opening width in mm = (Door width in mm x 2) + 30mm

Opening height in mm = (Door height in mm) + 90mm

Refer to Figure I.

Note: 90mm = door floor clearance 8mm + door to track clearance 28mm + header/track clearance 54mm
Finished studwall is 95mm thick plus plaster board used i.e. 95+12.5+12.5 = 120mm

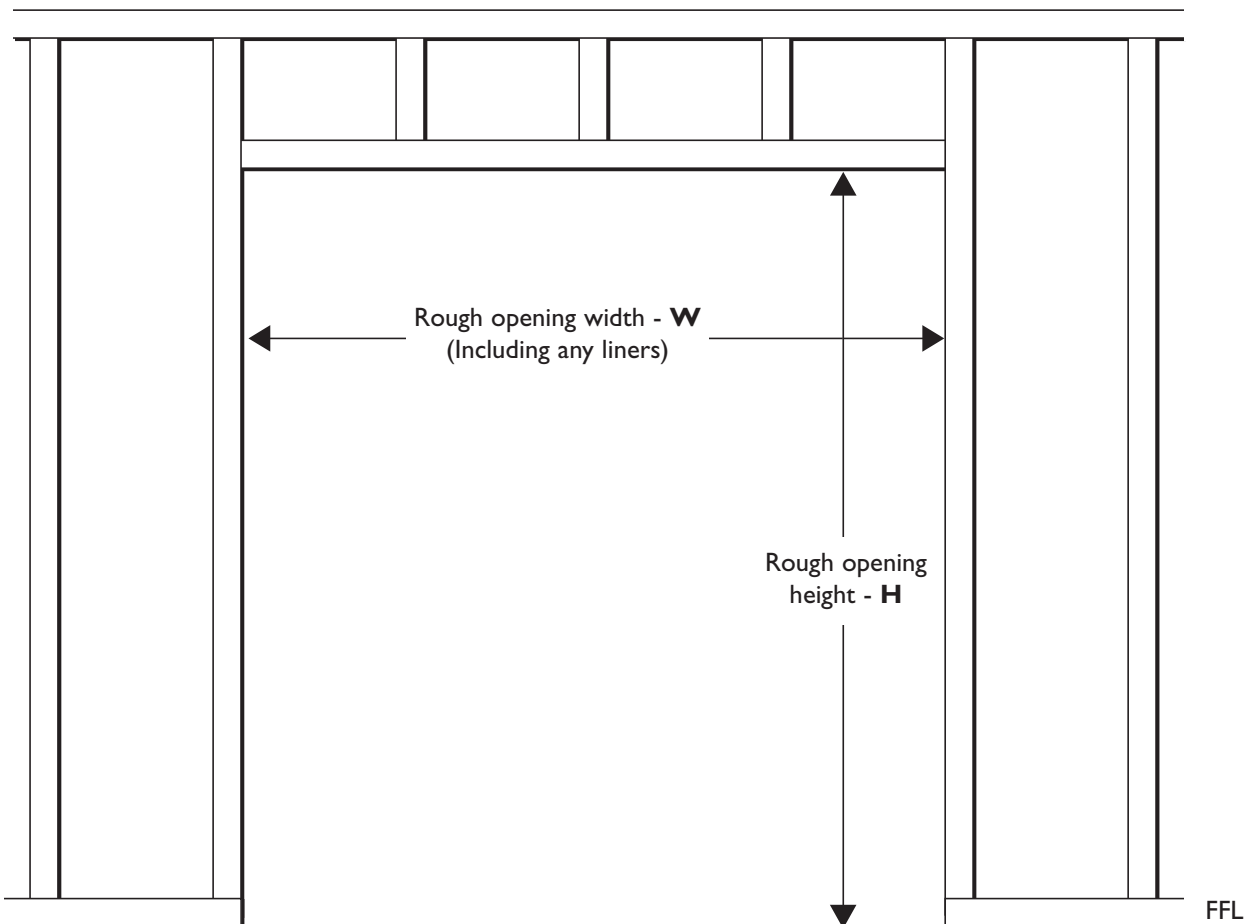

Figure I.

Quick look up table for opening sizes when using UK standard door sizes

Kit No.	Standard door size	Rough opening height - H	Rough opening width - W
PDK3	1981mm (78") high x 762mm (30") wide doors	2071mm	1554mm
PDK4	1981mm (78") high x 838mm (33") wide doors	2071mm	1706mm
PDK5	2040mm high x 762mm wide doors	2130mm	1554mm
PDK6	2040mm high x 826mm wide doors	2130mm	1682mm
PDK7	2040mm high x 726mm wide doors	2130mm	1482mm
PDK10	2315mm high x 930mm wide doors	2405mm	1890mm

Ensure that the rough opening is as square as possible to aid the fitting of the pocket door system, and so allowing the door to operate correctly when the installation is completed.

For double doors the rough opening width is as for one door multiplied by 2 and the 2 kits **MUST** be fixed directly to a suitable lintel. The two middle support brackets are not to be used.

Step 2 - Install Guide screws

Fit a guide screw - A to both frame uprights of the opening at the door height plus 28mm (measured from the Finished Floor Level - FFL). The screws should be fitted on the centre line of the cavity, refer to diagram for details (Fig 2.1). Fix both screws into the frame until the head of the screws are protruding about 3mm from the frame uprights.

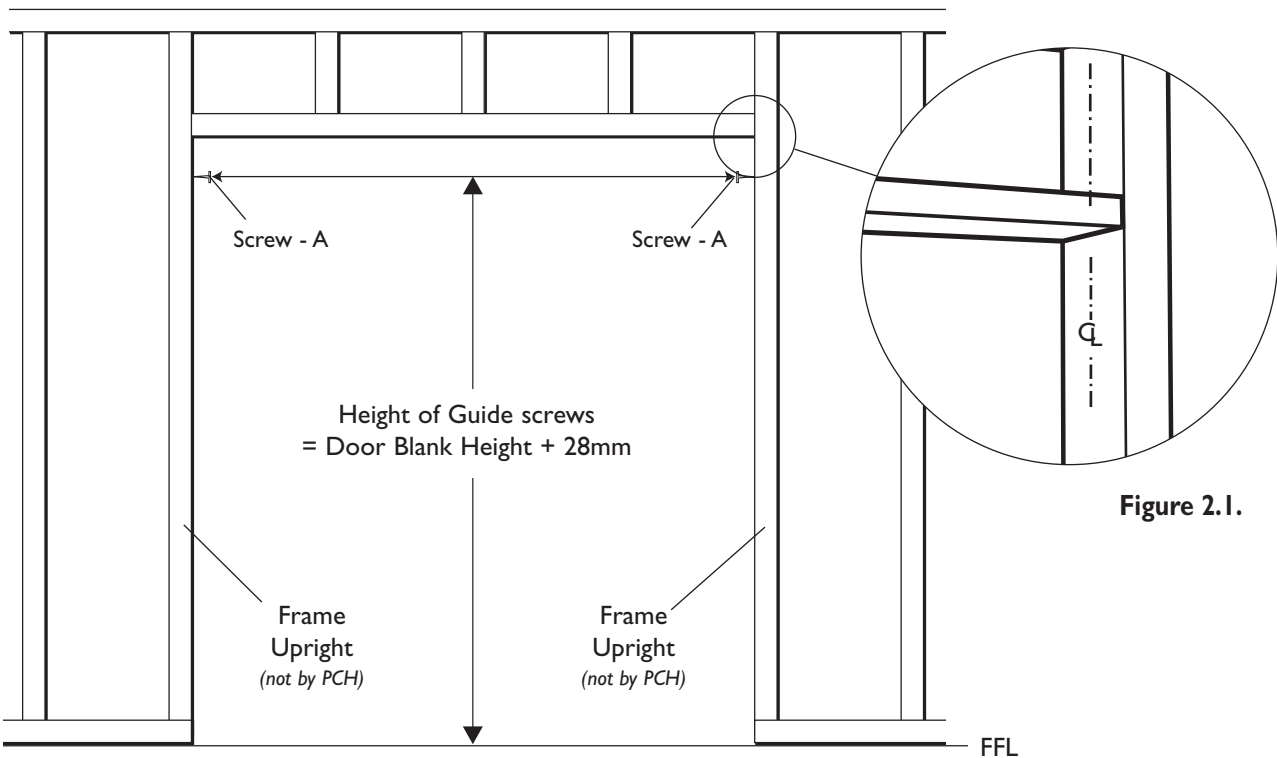

Figure 2.

Step 3 - Fit stud insert brackets

Using the Track and Head assembly as a template, mark on the floor between the vertical uprights with a soft pencil the lines as shown on diagram. These lines are the position of the stud insert bracket near the pocket opening. Fit remaining stud insert bracket half way between the rough opening upright and the first fitted stud insert bracket using screws - D (see Fig 5).

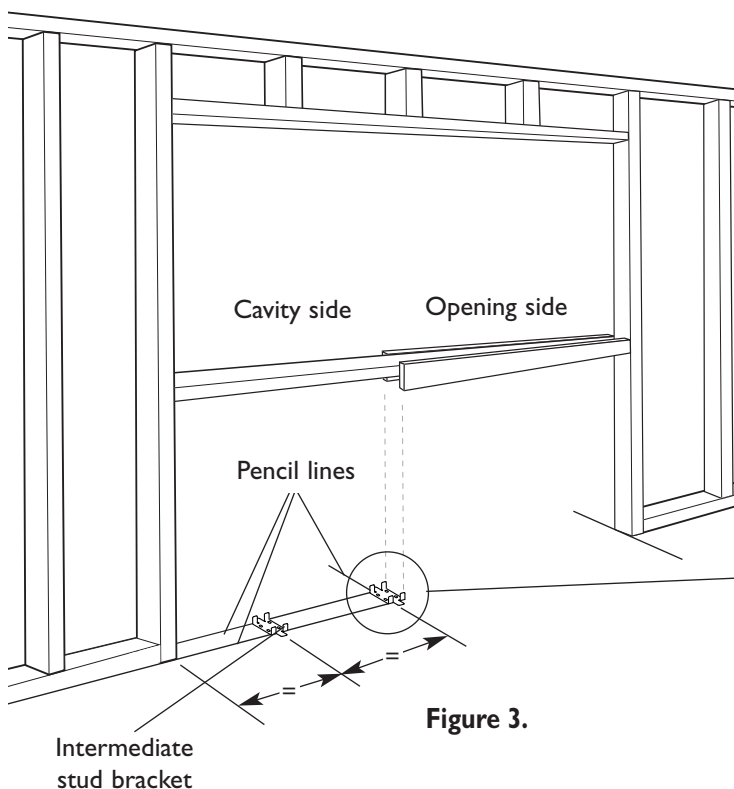

Figure 3.

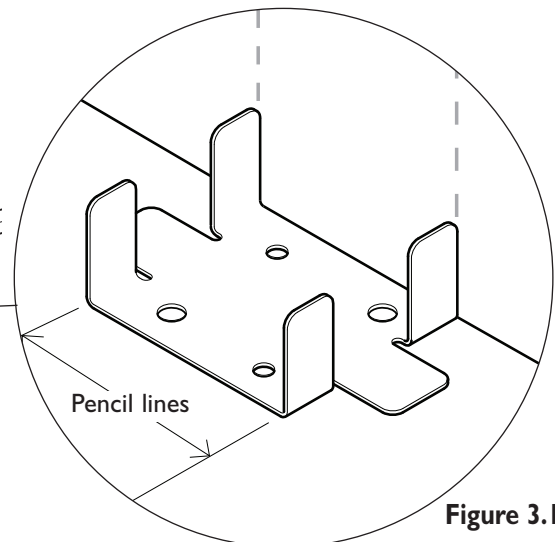

Figure 3.1.

Step 4 - Fitting the track & head assembly

Insert both hangers and clipstops into the track with the hanger 'ears' facing the clipstops at each end of the track, as shown in Fig. 4.1. Carefully lift the Head and Track assembly into the opening, then hook the metal brackets at both ends of the assembly on to the protruding guide screws fitted earlier. Then rotate the assembly into the final upright position (Fig.4). Whilst holding the assembly with one hand, screw the guide screws home at both ends. This should hold the Head and Track assembly in position with friction. Do not let go of the assembly if it is not held securely in place by the screws. Using a spirit level, check and correct the assembly ensuring it is level in all directions. Using screws B secure end brackets as indicated in Fig 4.2 & Fig 4.3.

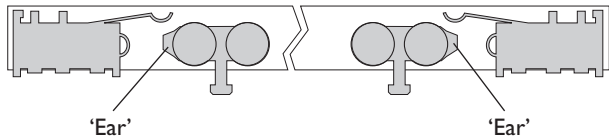

Figure 4.1.

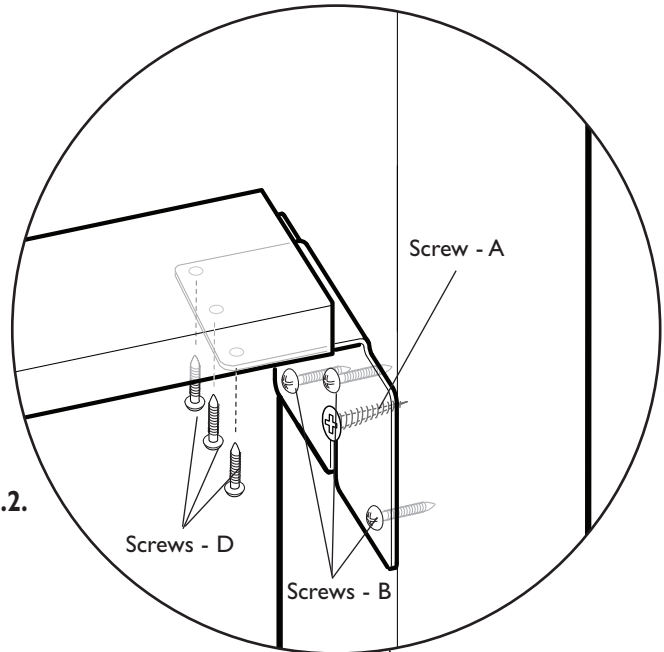

Figure 4.2.

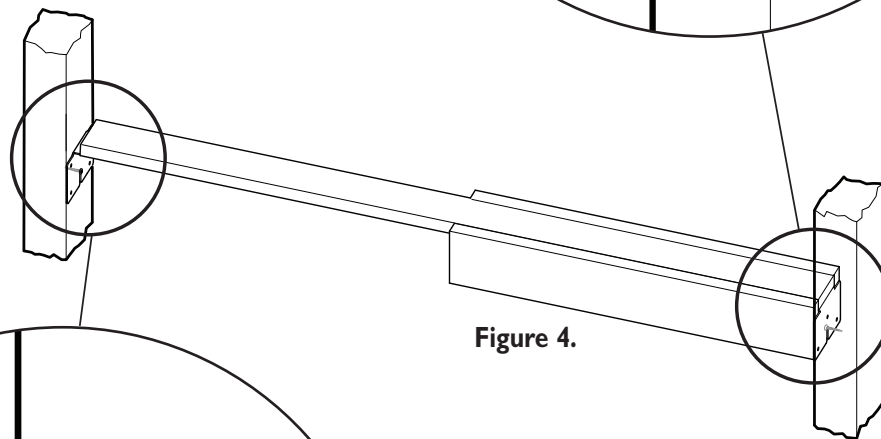

Figure 4.

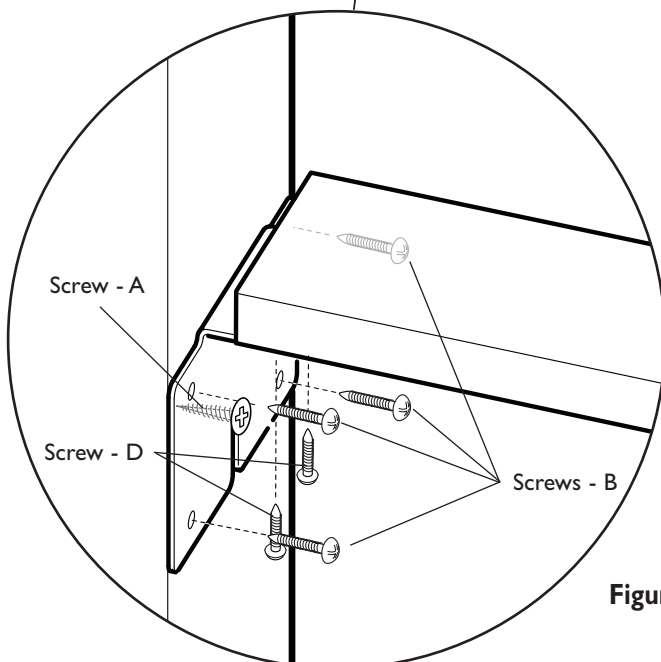

Figure 4.3.

Step 5 - Fit uprights

Slot first upright into stud insert bracket (as indicated in Figure 5.) and line the top of the upright against the side of the wooden head fascia. Check upright for vertical alignment with a spirit level, then screw the top of the upright to the wooden header board through the slots on the back of the upright. Repeat this for the second upright on the opposite side. Slot the third upright on the intermediate stud insert bracket, use a spirit level to check vertical alignment and then screw the top of the upright in to the wooden header board, through the slots on the back of the upright, (as indicated in figure 5.1).

Repeat step for the fourth upright on the opposite side.

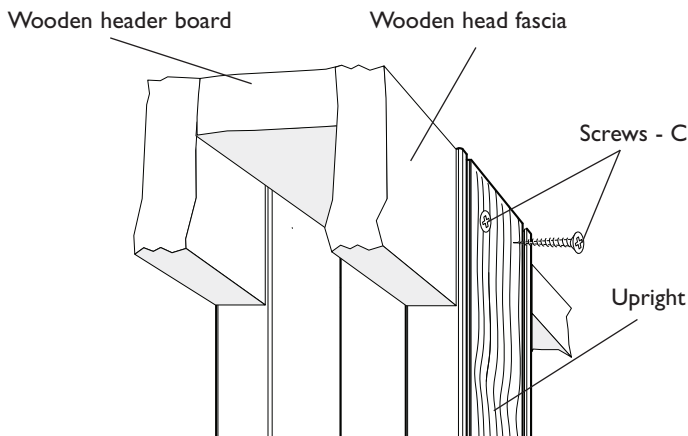

Figure 5.1.

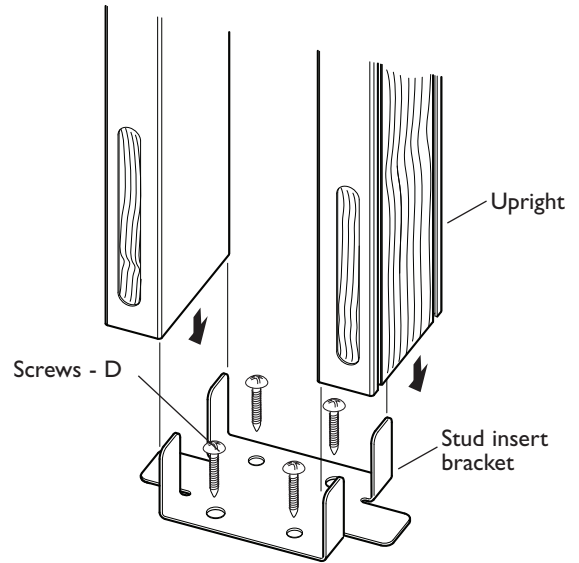

Figure 5.

Step 6 - Installing the guide

Using screws A position the guide assembly on the centre line of the cavity and in front the of stud insert bracket (figure 6.), checking the distance between the guide uprights is correct for the thickness of the door before screwing down to the floor, do not overtighten.

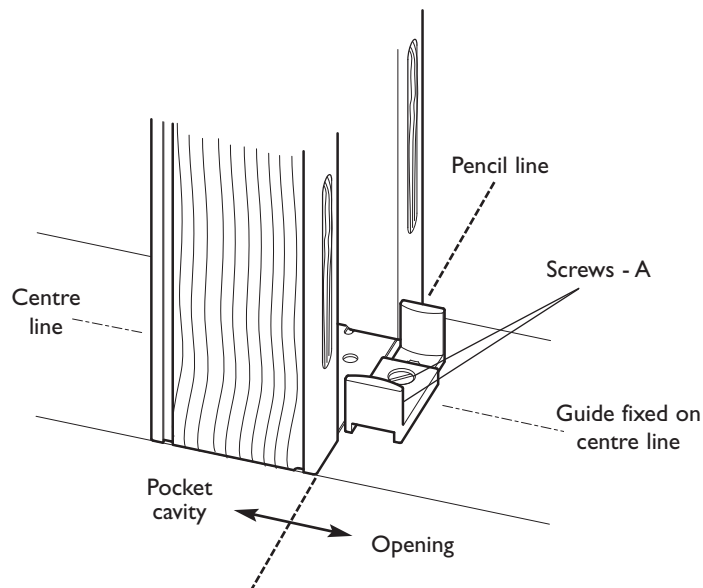
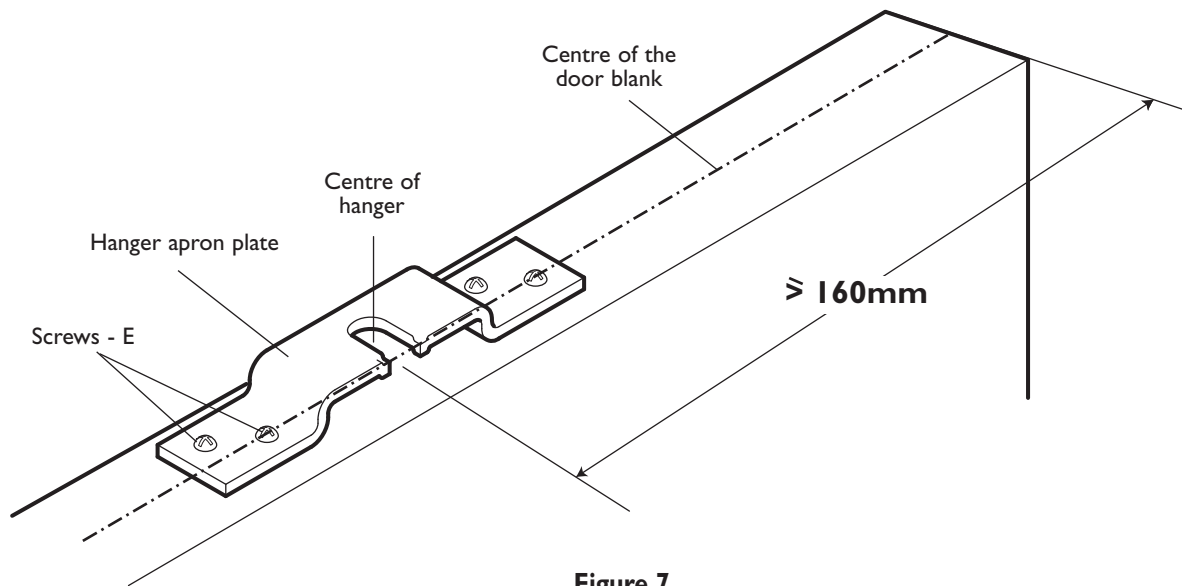

Figure 6.

Step 7 - Fitting the apron plates to the door

The centre of the apron plates must be no closer to the corners of the door than 160mm (figure 7). Position the centres of the apron plates along the centre of the door blank. Using screws E fix both the hanger apron plates on to the top face of the door.



Step 8 - Hanging of the door

Move the hangers within the track to align with the hanger apron plates on the door. Carefully hook the door, via the apron plates, on to the bolt heads hanging beneath the hangers. The bolts heads must be firmly seated on the underside of the apron plates behind the apron plate 'ears'. When in place adjust the door for height and alignment to the frame upright. When adjusted correctly screw down the lock nuts and tighten with spanner provided.

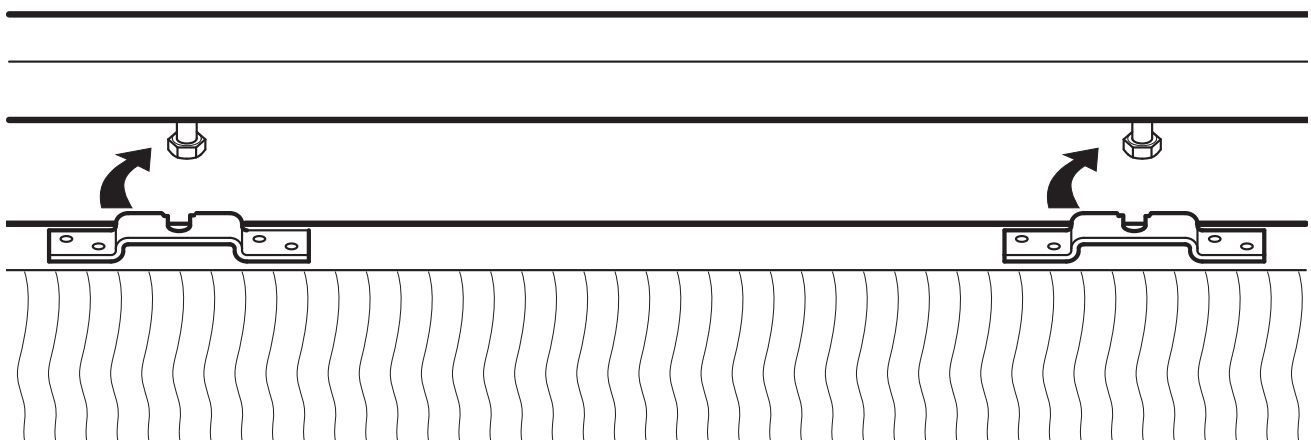

Step 9 - The finishing touches

Now with the door hung, position the clip stops to the desired positions within the track to limit the travel of the door, then tighten the clip stop bolts to fix in position. Remember that when the door is in the open position there will have to be enough of the door protruding from the pocket to pull the door shut. Alternatively the door may be flush with the pocket if used in conjunction with the Henderson 395 flush door lockset. Screw the rubber stop supplied into the frame upright on the pocket side, in alignment with door, at a height of approximately 50mm above the FFL (as indicated in figure 9). When the installation of the Henderson Pocket Door Kit is complete and the door is running smoothly, the plaster board panels can be fitted to the uprights to create the wall pocket, and then the desired mouldings and skirting board to finish off.

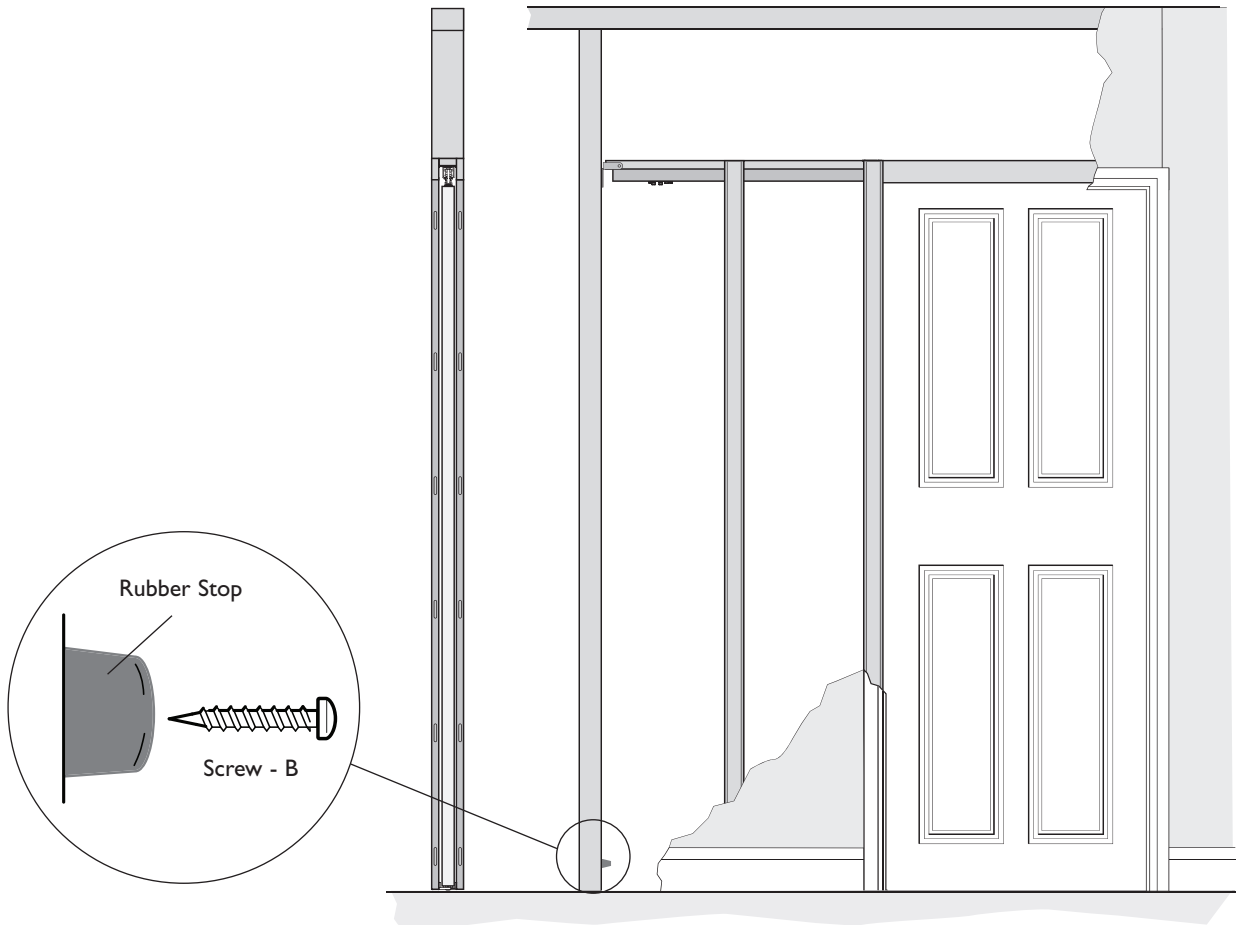

Figure 9.

Ironmongery available

To complement the installation of your Henderson Pocket Door System, we can supply a range of flush pulls and lock catches. Please contact P C Henderson sales department for further information.

Reducing the kit size

Kits can be reduced both in height and width to meet particular door sizes. To reduce the height of a kit cut down the uprights by the same amount, starting from the bottom of each upright (avoid cutting through the side slots). To reduce the width of the kit cut down the track and timber head assembly separately. Cut from the opening side by the difference between the kit door width and the door to be used in equal proportion. For further information contact the P.C. Henderson Technical Department.

